















































- 可提供对焊、承插焊、活接焊连接形式。
- 标准材料为不锈钢，其它材料可按需提供。
- 连接尺寸范围：1/8 " ~2 " 或6mm~ 38mm。

焊接管接头

● 焊接管接头

	Tube管承插焊直通接头	50		对焊四通接头	57
	Tube管承插焊异径直通接头	50		NPT外螺纹对焊直通接头	58
	Tube管承插焊直角接头	50		NPT内螺纹对焊直通接头	58
	Tube管承插焊45°弯头	51		米制外螺纹活接焊直通接头	59
	Tube管承插焊三通接头	51		NPT外螺纹活接焊直通接头	59
	Tube管承插焊四通接头	51		活接焊直通接头	60
	Tube管承插焊转NPT外螺纹直通接头	52		活接焊直通穿板接头	60
	Tube管承插焊转NPT内螺纹直通接头	52		米制外螺纹活接焊直角接头	60
	Tube管承插焊转NPT外螺纹直角接头	52		NPT外螺纹活接焊直角接头	61
	Tube管承插焊转NPT内螺纹直角接头	53		活接焊直角穿板接头	61
	Pipe公称管承插焊直通接头	53		活接焊三通接头	61
	Pipe公称管承插焊异径直通接头	53		活接焊四通接头	62
	Pipe公称管承插焊直角接头	54		活接焊螺母	62
	Pipe公称管承插焊45°弯头	54		活接焊短管平口式	62
	Pipe公称管承插焊三通接头	54		活接焊短管凸起式	62
	Pipe公称管承插焊四通接头	55		24°锥密封焊接短管	63
	Pipe公称管承插焊半管接头	55		24°锥密封焊接螺母	63
	Pipe公称管承插焊管帽	55		24°锥密封焊接外螺纹直通	63
	Pipe公称管承插焊活接	56		24°锥密封焊接外螺纹直角	64
	Tube管对焊活接	56		24°锥密封焊接三通	64
	对焊异径直通接头	56		24°锥密封焊接四通	64
	对焊45°弯头	56			
	对焊直角接头	57			
	对焊三通接头	57			

**1 材料**

SS	316
S	304
SL	316L
SC	碳钢
C	A105碳钢
B	黄铜
M2	合金20
M4	合金400
M6	合金600
T	PTFE

2 系列

U	直通接头
L	90度直角接头
BU	直通穿板接头
BL	90度直角穿板接头
V	45度接头
T	三通接头
H	四通接头
HJ	活接接头
CWB	公称管承插焊半管接头
DWM	公称管承插焊管帽
HJ	活接接头
HDM	活接焊螺母
HDA	活接焊管平口式
HDB	活接焊管凸起式

3 端口形式

C	双卡套端
T	NPT外螺纹
TF	NPT内螺纹
G	ISO平行外螺纹
GF	ISO平行内螺纹
GR	压力表接头
R	ISO锥形外螺纹/ZG
RC	ISO锥形内螺纹/ZGF
S	UN统一外螺纹/SAE/MS
SF	UN统一内螺纹/SAE/MS
M	米制外螺纹
MF	米制内螺纹
DWP	Pipe公称管对焊
CWP	Pipe公称管承插焊
DWT	Tube管对焊
CWT	Tube管承插焊
HDW	活接对焊
HZG	24度锥密封活接焊

4 端口尺寸

1	= 1/16"	2M	= 2mm
2	= 1/8"	3M	= 3mm
3	= 3/16"	6M	= 6mm
4	= 1/4"	8M	= 8mm
5	= 5/16"	10M	= 10mm
6	= 3/8"	12M	= 12mm
7	= 7/16"	14M	= 14mm
8	= 1/2"	15M	= 15mm
9	= 9/16"	16M	= 16mm
10	= 5/8"	18M	= 18mm
11	= 11/16"	19M	= 19mm
12	= 3/4"	20M	= 20mm
13	= 13/16"	22M	= 22mm
14	= 7/8"	25M	= 25mm
15	= 15/16"	28M	= 28mm
16	= 1"	32M	= 32mm
20	= 1 1/4"		

完整的尼克福斯接头型号编码,应包含:材料、系列、第一端口、第二端口四个部分,从左向右,各部分之间以“-”分隔。

端口之间的排列顺序原则:

- 1、第一端口优先使用卡套端,其次为螺纹、焊接、法兰。
- 2、两端口形式代码相同时,以公制尺寸的端口优先;为同种螺纹时,以外螺纹优先;同为焊接时,以公制管焊接优先,其次是英制Tube管焊接,最后是Pipe管焊接。
- 3、按1、2原则优先顺序相同的,以端口尺寸大的作为第一端口。
- 4、当直通或三通或四通端口完全相同时,以任意一个作为第一端口,并省略后面的端口。

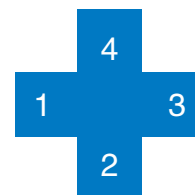

焊接管接头

Tube管承插焊直通接头

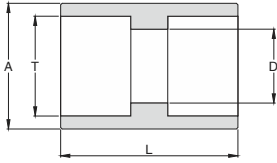

基本订购号	卡套管T (in/mm)	孔径D		外径A		长度L		压力等级 psi
		in	(mm)	in	(mm)	in	(mm)	
-U-CWT4	1/4	0.19	4.8	0.48	12.2	0.75	19.0	10000
-U-CWT6	3/8	0.28	7.1	0.60	15.2	0.88	22.4	8000
-U-CWT8	1/2	0.41	10.4	0.73	18.5	1.06	26.9	6600
-U-CWT10	5/8	0.50	12.7	0.86	21.8	1.18	30.0	6000
-U-CWT12	3/4	0.63	16.0	1.04	26.4	1.31	33.3	5900
-U-CWT16	1	0.88	22.4	1.36	34.5	1.44	36.6	5600
-U-CWT8M	8	0.24	6	0.55	14	0.79	20	3800
-U-CWT10M	10	0.31	8	0.63	16	0.87	22	3600
-U-CWT12M	12	0.39	10	0.75	19	0.98	25	3560
-U-CWT14M	14	0.43	11	0.83	21	1.06	27	3500
-U-CWT16M	16	0.47	12	0.94	24	1.14	29	3160
-U-CWT18M	18	0.55	14	1.02	26	1.26	32	2870
-U-CWT20M	20	0.59	15	1.14	29	1.34	34	2700
-U-CWT25M	25	0.75	19	1.34	34	1.42	36	2640

Tube管承插焊异径直通接头

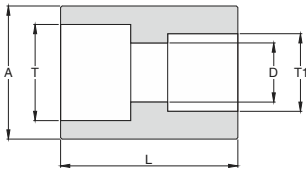

基本订购号	管径T (in/mm)	管径T1 (in/mm)	孔径D		外径A		长度L		压力等级 psi
			in	(mm)	in	(mm)	in	(mm)	
-U-CWT6-CWT4	3/8	1/4	0.19	4.8	0.60	15.2	0.88	22.4	10000
-U-CWT8-CWT4	1/2	1/4	0.19	4.8	0.73	18.5	1.06	26.9	8000
-U-CWT8-CWT6	1/2	3/8	0.28	7.1	0.73	18.5	1.06	26.9	6000
-U-CWT12-CWT6	3/4	3/8	0.28	7.1	1.04	26.4	1.31	33.3	5600
-U-CWT12-CWT8	3/4	1/2	0.41	10.4	1.04	26.4	1.31	33.3	3600
-U-CWT10M-CWT8M	10	8	0.24	6	0.63	16	0.87	22	3800
-U-CWT12M-CWT8M	12	8	0.24	6	0.75	19	0.98	25	3800
-U-CWT12M-CWT10M	12	10	0.31	8	0.75	19	0.98	25	3600
-U-CWT14M-CWT10M	14	10	0.31	8	0.83	21	1.06	27	3600
-U-CWT14M-CWT12M	14	12	0.39	10	0.83	21	1.06	27	3560
-U-CWT16M-CWT12M	16	12	0.39	10	0.94	24	1.14	29	3560
-U-CWT20M-CWT16M	20	16	0.47	12	1.14	29	1.34	34	3160
-U-CWT25M-CWT20M	25	20	0.59	15	1.34	34	1.42	36	2700

Tube管承插焊直角接头

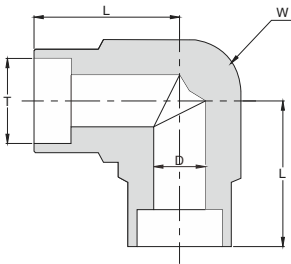

基本订购号	卡套管T (in/mm)	孔径D		六角W		长度L		压力等级 psi
		in	(mm)	in	(mm)	in	(mm)	
-L-CWT4	1/4	0.19	4.8	0.50	12.7	0.75	19	10000
-L-CWT6	3/8	0.28	7.1	0.69	17.5	0.94	24	8000
-L-CWT8	1/2	0.41	10.4	0.75	19.0	1.02	26	6600
-L-CWT10	5/8	0.50	12.7	0.94	23.8	1.10	28	6000
-L-CWT12	3/4	0.63	16.0	1.06	27.0	1.18	30	5900
-L-CWT16	1	0.88	22.4	1.30	33.0	1.42	36	5600
-L-CWT8M	8	0.24	6	0.56	14.3	0.83	21	3800
-L-CWT10M	10	0.31	8	0.69	17.5	0.94	24	3600
-L-CWT12M	12	0.39	10	0.75	19.0	1.02	26	3560
-L-CWT14M	14	0.43	11	0.82	20.8	1.02	26	3500
-L-CWT16M	16	0.47	12	0.94	23.8	1.10	28	3160
-L-CWT18M	18	0.55	14	1.06	27.0	1.18	30	2870
-L-CWT20M	20	0.59	15	1.06	27.0	1.18	30	2700
-L-CWT25M	25	0.75	19	1.30	33.0	1.42	36	2640

Tube管承插焊45°弯头

基本订购号	卡套管T (in/mm)	孔径D		六角W		长度L		压力等级 psi
		in	(mm)	in	(mm)	in	(mm)	
-V-CWT4	1/4	0.19	4.8	0.50	12.7	0.75	19	10000
-V-CWT6	3/8	0.28	7.1	0.69	17.5	0.94	24	8000
-V-CWT8	1/2	0.41	10.4	0.75	19.0	1.02	26	6600
-V-CWT10	5/8	0.50	12.7	0.94	23.8	1.10	28	6000
-V-CWT12	3/4	0.63	16.0	1.06	27.0	1.18	30	5900
-V-CWT16	1	0.88	22.4	1.30	33.0	1.42	36	5600
-V-CWT8M	8	0.24	6	0.56	14.3	0.83	21	3800
-V-CWT10M	10	0.31	8	0.69	17.5	0.94	24	3600
-V-CWT12M	12	0.39	10	0.75	19.0	1.02	26	3560
-V-CWT14M	14	0.43	11	0.82	20.8	1.02	26	3500
-V-CWT16M	16	0.47	12	0.94	23.8	1.10	28	3160
-V-CWT18M	18	0.55	14	1.06	27.0	1.18	30	2870
-V-CWT20M	20	0.59	19	1.06	27.0	1.18	30	2700
-V-CWT25M	25	0.75	15	1.30	33.0	1.42	36	2640

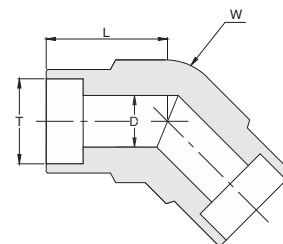

Tube管承插焊三通接头

基本订购号	卡套管T (in/mm)	孔径D		六角W		长度L		压力等级 psi
		in	(mm)	in	(mm)	in	(mm)	
-T-CWT4	1/4	0.19	4.8	0.50	12.7	0.75	19	10000
-T-CWT6	3/8	0.28	7.1	0.69	17.5	0.94	24	8000
-T-CWT8	1/2	0.41	10.4	0.75	19.0	1.02	26	6600
-T-CWT10	5/8	0.50	12.7	0.94	23.8	1.10	28	6000
-T-CWT12	3/4	0.63	16.0	1.06	27.0	1.18	30	5900
-T-CWT16	1	0.88	22.4	1.30	33.0	1.42	36	5600
-T-CWT8M	8	0.24	6	0.56	14.3	0.83	21	3800
-T-CWT10M	10	0.31	8	0.69	17.5	0.94	24	3600
-T-CWT12M	12	0.39	10	0.75	19.0	1.02	26	3560
-T-CWT14M	14	0.43	11	0.82	20.8	1.02	26	3500
-T-CWT16M	16	0.47	12	0.94	23.8	1.10	28	3160
-T-CWT18M	18	0.55	14	1.06	27.0	1.18	30	2870
-T-CWT20M	20	0.59	15	1.06	27.0	1.18	30	2700
-T-CWT25M	25	0.75	19	1.30	33.0	1.42	36	2640

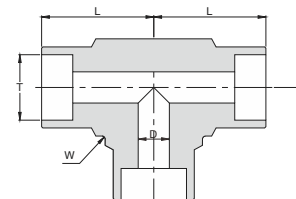

Tube管承插焊四通接头

基本订购号	卡套管T (in/mm)	孔径D		六角W		长度L		压力等级 psi
		in	(mm)	in	(mm)	in	(mm)	
-H-CWT4	1/4	0.19	4.8	0.50	12.7	0.75	19	10000
-H-CWT6	3/8	0.28	7.1	0.69	17.5	0.94	24	8000
-H-CWT8	1/2	0.41	10.4	0.75	19.0	1.02	26	6600
-H-CWT10	5/8	0.50	12.7	0.94	23.8	1.10	28	6000
-H-CWT12	3/4	0.63	16.0	1.06	27.0	1.18	30	5900
-H-CWT16	1	0.88	22.4	1.30	33.0	1.42	36	5600
-H-CWT8M	8	0.24	6	0.56	14.3	0.83	21	3800
-H-CWT10M	10	0.31	8	0.69	17.5	0.94	24	3600
-H-CWT12M	12	0.39	10	0.75	19.0	1.02	26	3560
-H-CWT14M	14	0.43	11	0.82	20.8	1.02	26	3500
-H-CWT16M	16	0.47	12	0.94	23.8	1.10	28	3160
-H-CWT18M	18	0.55	14	1.06	27.0	1.18	30	2870
-H-CWT20M	20	0.59	15	1.06	27.0	1.18	30	2700
-H-CWT25M	25	0.75	19	1.30	33.0	1.42	36	2640

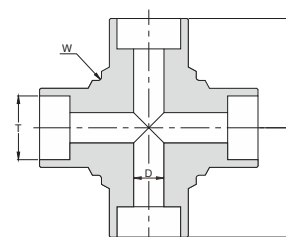

焊接管接头

Tube管承插焊转NPT外螺纹直通接头

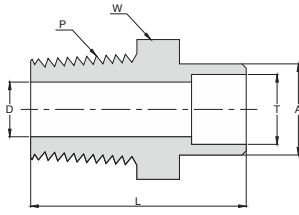

基本订购号	管径T (in/mm)	螺纹P NPT	孔径D in (mm)	外径A in (mm)	长度L in (mm)	六角W in (mm)	压力等级 psi
-U-T4-CWT4	1/4	1/4	0.19 4.8	0.48 12.2	1.14 29	0.56 14.2	3800
-U-T4-CWT6	3/8	1/4	0.28 7.1	0.60 15.2	1.26 32	0.62 15.8	3800
-U-T6-CWT6	3/8	3/8	0.28 7.1	0.60 15.2	1.26 32	0.69 17.4	3700
-U-T8-CWT6	3/8	1/2	0.28 7.1	0.60 15.2	1.46 37	0.87 22.2	3700
-U-T4-CWT8	1/2	1/4	0.41 10.4	0.73 18.5	1.30 33	0.75 19.0	3100
-U-T6-CWT8	1/2	3/8	0.41 10.4	0.73 18.5	1.30 33	0.75 19.0	3100
-U-T8-CWT8	1/2	1/2	0.41 10.4	0.73 18.5	1.50 38	0.87 22.2	3100
-U-T8-CWT12	3/4	1/2	0.63 16.0	1.04 26.4	1.73 43.9	1.06 27.0	2900
-U-T4-CWT8M	8	1/4	0.24 6	0.55 14	1.18 30	0.56 14.2	3800
-U-T4-CWT12M	12	1/4	0.39 10	0.73 18.5	1.26 32	0.75 19.0	3560
-U-T6-CWT12M	12	3/8	0.39 10	0.73 18.5	1.34 34	0.75 19.0	3560
-U-T8-CWT12M	12	1/2	0.39 10	0.73 18.5	1.42 36	0.87 22.2	3560
-U-T6-CWT14M	14	3/8	0.43 11	0.81 20.5	1.42 36	0.87 22.2	3500
-U-T8-CWT14M	14	1/2	0.43 11	0.81 20.5	1.50 38	0.87 22.2	3500
-U-T8-CWT16M	16	1/2	0.47 12	0.93 23.5	1.54 39	0.94 24.0	3160
-U-T8-CWT20M	20	1/2	0.59 15	1.04 26.5	1.73 43.9	1.06 27.0	2760

Tube管承插焊转NPT内螺纹直通接头

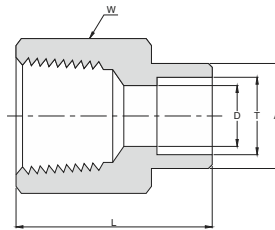

基本订购号	管径T (in/mm)	螺纹P NPT	孔径D in (mm)	外径A in (mm)	长度L in (mm)	六角W in (mm)	压力等级 psi
-U-TF2-CWT2	1/8	1/8	0.11 2.8	0.35 9.0	0.83 21.1	0.56 14.2	3080
-U-TF2-CWT4	1/4	1/8	0.19 4.8	0.48 12.2	1.05 26.7	0.56 14.2	3080
-U-TF4-CWT4	1/4	1/4	0.19 4.8	0.48 12.2	1.18 30.0	0.75 19.0	3100
-U-TF4-CWT6	3/8	1/4	0.28 7.1	0.60 15.2	1.24 31.5	0.75 19.0	3100
-U-TF6-CWT8	1/2	3/8	0.41 10.4	0.73 18.5	1.36 34.5	0.87 22.2	2500
-U-TF8-CWT8	1/2	1/2	0.41 10.4	0.73 18.5	1.59 40.4	1.06 27.0	2320
-U-TF12-CWT12	3/4	3/4	0.63 16.0	1.04 26.4	1.73 43.9	1.31 33.3	2180
-U-TF4-CWT8M	8	1/4	0.24 6	0.55 14	1.24 31.5	0.75 19.0	3100
-U-TF4-CWT10M	10	1/4	0.31 8	0.63 16	1.26 32.0	0.75 19.0	3100
-U-TF6-CWT14M	14	3/8	0.43 11	0.81 20.5	1.38 35.0	0.87 22.2	2500
-U-TF8-CWT14M	14	1/2	0.43 11	0.81 20.5	1.61 41.0	1.06 27.0	2300
-U-TF8-CWT16M	16	1/2	0.47 12	0.93 23.5	1.69 43.0	1.06 27.0	2300
-U-TF12-CWT20M	20	3/4	0.59 15	1.04 26.5	1.73 44.0	1.31 33.3	2300
-U-TF12-CWT25M	25	3/4	0.75 19	1.34 34.0	1.81 46.0	1.31 33.3	2300

Tube管承插焊转NPT外螺纹直角接头

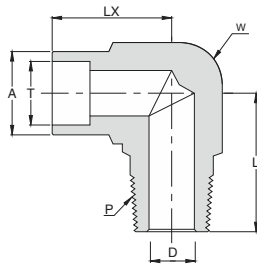

基本订购号	管径T (in/mm)	螺纹P NPT	孔径D in (mm)	外径A in (mm)	长度L in (mm)	长度Lx in (mm)	六角W in (mm)	压力等级 psi
-L-T4-CWT4	1/4	1/4	0.19 4.8	0.48 12.2	0.94 24	0.83 21	0.56 14.2	3800
-L-T4-CWT6	3/8	1/4	0.28 7.1	0.60 15.2	1.02 26	0.91 23	0.69 17.4	3800
-L-T6-CWT6	3/8	3/8	0.28 7.1	0.60 15.2	1.02 26	0.94 24	0.69 17.4	3700
-L-T8-CWT6	3/8	1/2	0.28 7.1	0.60 15.2	1.34 34	1.02 26	0.94 23.8	3650
-L-T8-CWT8	1/2	1/2	0.41 10.4	0.73 18.5	1.34 34	1.02 26	0.94 23.8	3100
-L-T12-CWT12	3/4	3/4	0.63 16	1.04 26.4	1.46 37	1.18 30	1.06 27.0	2950
-L-T4-CWT8M	8	1/4	0.24 6	0.55 14	0.94 24	0.83 21	0.56 14.2	3100
-L-T4-CWT10M	10	1/4	0.31 8	0.63 16	1.02 26	0.91 23	0.69 17.4	3100
-L-T6-CWT12M	12	3/8	0.39 10	0.73 18.5	1.10 28	1.02 26	0.75 19.0	2500
-L-T8-CWT14M	14	1/2	0.43 11	0.81 20.5	1.34 34	1.02 26	0.94 23.8	2300
-L-T8-CWT16M	16	1/2	0.47 12	0.93 23.5	1.34 34	1.02 26	0.94 23.8	2300
-L-T8-CWT20M	20	3/4	0.59 15	1.04 26.5	1.46 37	1.18 30	1.06 27	2300
-L-T12-CWT25M	25	3/4	0.75 19	1.34 34	1.81 46	1.42 36	1.31 33.3	2300

Tube管承插焊转NPT内螺纹直角接头

基本订购号	管径T (in/mm)	螺纹P NPT	孔径D in (mm)	外径A in (mm)	长度L in (mm)	长度Lx in (mm)	六角W in (mm)	压力等级 psi
-L-TF4-CWT4	1/4	1/4	0.19 4.8	0.48 12.2	1.02 26	0.91 23	0.69 17.4	3000
-L-TF6-CWT4	1/4	3/8	0.19 4.8	0.48 12.2	1.30 33	1.02 26	0.82 20.8	2800
-L-TF6-CWT6	3/8	3/8	0.28 7.1	0.60 15.2	1.30 33	1.02 26	0.82 20.8	2500
-L-TF8-CWT6	3/8	1/2	0.28 7.1	0.60 15.2	1.46 37	1.18 30	1.06 27.0	2100
-L-TF8-CWT8	1/2	1/2	0.41 10.4	0.73 18.5	1.46 37	1.18 30	1.06 27.0	2100
-L-TF12-CWT12	3/4	3/4	0.63 16	1.04 26.4	1.81 46	1.42 36	1.31 33.3	2100
-L-TF4-CWT8M	8	1/4	0.24 6	0.55 14	1.02 26	0.91 23	0.69 17.4	3000
-L-TF4-CWT10M	10	1/4	0.31 8	0.63 16	1.02 26	0.91 23	0.69 17.4	3000
-L-TF6-CWT12M	12	3/8	0.39 10	0.73 18.5	1.30 33	1.02 26	0.82 20.8	2800
-L-TF6-CWT14M	14	3/8	0.43 11	0.81 20.5	1.30 33	1.02 26	0.82 20.8	2600
-L-TF8-CWT16M	16	1/2	0.47 12	0.93 23.5	1.46 37	1.18 30	1.06 27	2100
-L-TF8-CWT20M	20	1/2	0.55 14	1.02 26	1.46 37	1.18 30	1.06 27	2100

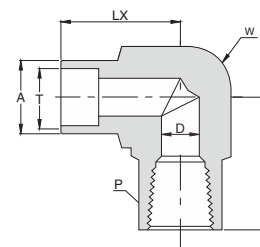

Pipe公称管承插焊直通接头

基本订购号	公称管 in	焊孔P in (mm)	外径D in (mm)	孔径d in (mm)	长度L in (mm)	压力等级 psi
-U-CWP4	1/4	0.55 14	0.79 20	0.31 8	0.87 22	3000
-U-CWP6	3/8	0.67 17	0.94 24	0.39 10	1.02 26	3000
-U-CWP8	1/2	0.85 21.7	1.14 29	0.59 15	1.26 32	3000
-U-CWP12	3/4	1.06 27.0	1.40 35.5	0.79 20	1.42 36	3000
-U-CWP16	1	1.33 33.8	1.72 43.8	1.02 26	1.65 42	3000
-U-CWP20	1 1/4	1.67 42.5	2.09 53.1	1.34 34	1.81 46	3000
-U-CWP24	1 1/2	1.91 48.6	2.35 59.6	1.57 40	1.97 50	3000
-U-CWP4-X	1/4	0.55 14	2.87 22	0.24 6	0.87 22	6000
-U-CWP6-X	3/8	0.67 17	1.06 27	0.31 8	1.02 26	6000
-U-CWP8-x	1/2	0.85 21.7	1.30 33	0.43 11	1.26 32	6000
-U-CWP12-x	3/4	1.06 27.0	1.54 39	0.58 14.8	1.42 36	6000
-U-CWP16-x	1	1.33 33.8	1.89 48	0.79 20	1.65 42	6000
-U-CWP20-x	1 1/4	1.67 42.5	2.24 57	1.13 28.7	1.81 46	6000
-U-CWP24-x	1 1/2	1.91 48.6	2.52 64	1.31 33.2	1.97 50	6000

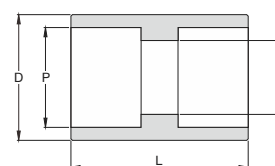

后面加-x为加厚型

Pipe公称管承插焊异径直通接头

基本订购号	公称管 in	焊孔P1 in (mm)	焊孔P2 in (mm)	外径D in (mm)	孔径d in (mm)	长度L in (mm)	压力等级 psi
-U-CWP6-CWP4	1/4 - 3/8	0.55 14	0.67 17	0.94 24	0.31 8	1.02 26	3000
-U-CWP8-CWP6	3/8 - 1/2	0.67 17	0.85 21.7	1.14 29	0.39 10	1.26 32	3000
-U-CWP12-CWP8	1/2 - 3/4	0.85 21.7	1.06 27	1.40 35.5	0.59 15	1.42 36	3000
-U-CWP16-CWP12	3/4 - 1	1.06 27	1.33 33.8	1.72 43.8	0.79 20	1.65 42	3000
-U-CWP20-CWP16	1 - 1 1/4	1.33 33.8	1.67 42.5	2.09 53.1	1.02 26	1.81 46	3000
-U-CWP24-CWP20	1 1/4 - 1 1/2	1.67 42.5	1.91 48.6	2.35 59.6	1.34 34	1.97 50	3000
-U-CWP24-CWP12	1 1/4 - 3/4	1.91 48.6	1.06 27	2.35 59.6	0.79 20	1.97 50	3000
-U-CWP24-CWP16	1 1/2 - 1	1.91 48.6	1.33 33.8	2.35 59.6	1.02 26	1.97 50	3000
-U-CWP6-CWP4-X	1/4 - 3/8	0.55 14	0.67 17	1.06 27	0.24 6	1.02 26	6000
-U-CWP8-CWP6-X	3/8 - 1/2	0.67 17	0.85 21.7	1.30 33	0.31 8	1.26 32	6000
-U-CWP12-CWP8-X	1/2 - 3/4	0.85 21.7	1.06 27	1.54 39	0.43 11	1.42 36	6000
-U-CWP16-CWP12-X	3/4 - 1	1.06 27	1.33 33.8	1.89 48	0.58 14.8	1.65 42	6000
-U-CWP20-CWP16-X	1 - 1 1/4	1.33 33.8	1.67 42.5	2.24 57	0.79 20	1.81 46	6000
-U-CWP24-CWP20-X	1 1/4 - 1 1/2	1.67 42.5	1.91 48.6	2.52 64	1.13 28.7	1.97 50	6000
-U-CWP20-CWP12-X	1 1/4 - 3/4	1.91 48.6	1.06 27	2.52 64	0.58 14.8	1.97 50	6000
-U-CWP24-CWP16-X	1 1/2 - 1	1.91 48.6	1.33 33.8	2.52 64	0.79 20	1.97 50	6000

后面加-x为加厚型

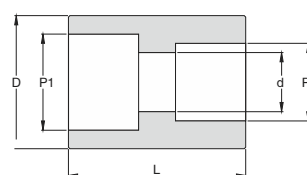

焊接管接头

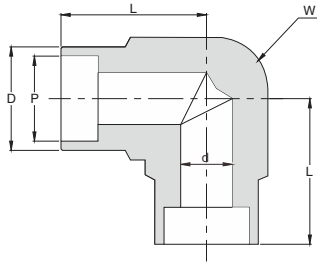

Pipe公称管承插焊直角接头

基本订购号	公称管 in	焊孔P in (mm)	外径D in (mm)	孔径d in (mm)	长度L in (mm)	六角W in (mm)	压力等级 psi
-L-CWP4	1/4	0.55 14	0.79 20	0.31 8	1.02 26	0.82 20.8	3000
-L-CWP6	3/8	0.67 17	0.94 24	0.39 10	1.10 28	0.94 24	3000
-L-CWP8	1/2	0.85 21.7	1.14 29	0.59 15	1.18 30	1.18 30	3000
-L-CWP12	3/4	1.06 27	1.40 35.5	0.79 20	1.42 36	1.30 33.0	3000
-L-CWP16	1	1.33 33.8	1.72 43.8	1.02 26	1.50 38	1.50 38.0	3000
-L-CWP20	1 1/4	1.67 42.5	2.09 53.1	1.34 34	1.73 44	1.81 46.0	3000
-L-CWP24	1 1/2	1.91 48.6	2.35 59.6	1.57 40	1.89 48	1.97 50	3000
-L-CWP4-X	1/4	0.55 14	0.87 22	0.24 6	1.02 26	0.94 23.8	3000
-L-CWP6-X	3/8	0.67 17	1.06 27	0.31 8	1.10 28	1.06 27	6000
-L-CWP8-X	1/2	0.85 21.7	1.30 33	0.43 11	1.18 30	1.18 30	6000
-L-CWP12-X	3/4	1.06 27	1.54 39	0.58 14.8	1.42 36	1.30 33.0	6000
-L-CWP16-X	1	1.33 33.8	1.89 48	0.79 20	1.50 38	1.81 46	6000
-L-CWP20-X	1 1/4	1.67 42.5	2.24 57	1.13 28.7	1.73 44	1.97 50	6000
-L-CWP24-X	1 1/2	1.91 48.6	2.52 64	1.31 33.2	1.89 48	2.28 58	6000

后面加-x为加厚型

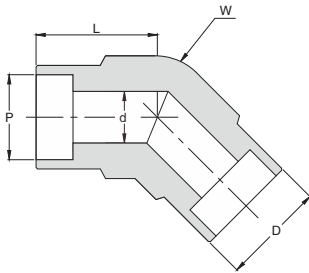

Pipe公称管承插焊45° 弯头

基本订购号	公称管 in	焊孔P in (mm)	外径D in (mm)	孔径d in (mm)	长度L in (mm)	六角W in (mm)	压力等级 psi
-V-CWP4	1/4	0.55 14	0.79 20	0.31 8	1.02 26	0.82 20.8	3000
-V-CWP6	3/8	0.67 17	0.94 24	0.39 10	1.10 28	0.94 23.8	3000
-V-CWP8	1/2	0.85 21.7	1.14 29	0.59 15	1.18 30	1.18 30	3000
-V-CWP12	3/4	1.06 27	1.40 35.5	0.79 20	1.42 36	1.30 33.0	3000
-V-CWP16	1	1.33 33.8	1.72 43.8	1.02 26	1.50 38	1.50 38.0	3000
-V-CWP20	1 1/4	1.67 42.5	2.09 53.1	1.34 34	1.73 44	1.81 46.0	3000
-V-CWP24	1 1/2	1.91 48.6	2.35 59.6	1.57 40	1.89 48	1.97 50	3000
-V-CWP4-X	1/4	0.55 14	0.87 22	0.24 6	1.02 26	0.94 23.8	3000
-V-CWP6-X	3/8	0.67 17	1.06 27	0.31 8	1.10 28	1.06 27	6000
-V-CWP8-X	1/2	0.85 21.7	1.30 33	0.43 11	1.18 30	1.18 30	6000
-V-CWP12-X	3/4	1.06 27	1.54 39	0.58 14.8	1.42 36	1.30 33.0	6000
-V-CWP16-X	1	1.33 33.8	1.89 48	0.79 20	1.50 38.0	1.81 46.0	6000
-V-CWP20-X	1 1/4	1.67 42.5	2.24 57	1.13 28.7	1.73 44	1.97 50	6000
-V-CWP24-X	1 1/2	1.91 48.6	2.52 64	1.31 33.2	1.89 48	2.28 58	6000

后面加-x为加厚型

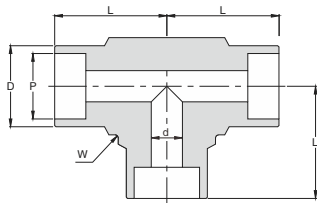

Pipe公称管承插焊三通接头

基本订购号	公称管 in	焊孔P in (mm)	外径D in (mm)	孔径d in (mm)	长度L in (mm)	六角W in (mm)	压力等级 psi
-T-CWP4	1/4	0.55 14	0.79 20	0.31 8	1.02 26	0.82 20.8	3000
-T-CWP6	3/8	0.67 17	0.94 24	0.39 10	1.10 28	0.94 23.8	3000
-T-CWP8	1/2	0.85 21.7	1.14 29	0.59 15	1.18 30	1.18 30	3000
-T-CWP12	3/4	1.06 27	1.40 35.5	0.79 20	1.42 36	1.30 33.0	3000
-T-CWP16	1	1.33 33.8	1.72 43.8	1.02 26	1.50 38	1.50 38.0	3000
-T-CWP20	1 1/4	1.67 42.5	2.09 53.1	1.34 34	1.73 44	1.81 46.0	3000
-T-CWP24	1 1/2	1.91 48.6	2.35 59.6	1.57 40	1.89 48	1.97 50	3000
-T-CWP4-X	1/4	0.55 14	0.87 22	0.24 6	1.02 26	0.94 23.8	3000
-T-CWP6-X	3/8	0.67 17	1.06 27	0.31 8	1.10 28	1.06 27	6000
-T-CWP8-X	1/2	0.85 21.7	1.30 33	0.43 11	1.18 30	1.18 30	6000
-T-CWP12-X	3/4	1.06 27	1.54 39	0.58 14.8	1.42 36	1.30 33.0	6000
-T-CWP16-X	1	1.33 33.8	1.89 48	0.79 20	1.50 38	1.81 46.0	6000
-T-CWP20-X	1 1/4	1.67 42.5	2.24 57	1.13 28.7	1.73 44	1.97 50	6000
-T-CWP24-X	1 1/2	1.91 48.6	2.52 64	1.31 33.2	1.89 48	2.28 58	6000

后面加-x为加厚型

Pipe公称管承插焊四通接头

基本订购号	公称管 in	焊孔P in (mm)	外径D in (mm)	孔径d in (mm)	长度L in (mm)	六角W in (mm)	压力等级 psi
-H-CWP4	1/4	0.55 14	0.79 20	0.31 8	1.02 26	0.82 20.8	3000
-H-CWP6	3/8	0.67 17	0.94 24	0.39 10	1.10 28	0.94 23.8	3000
-H-CWP8	1/2	0.85 21.7	1.14 29	0.59 15	1.18 30	1.18 30	3000
-H-CWP12	3/4	1.06 27	1.40 35.5	0.79 20	1.42 36	1.30 33.0	3000
-H-CWP16	1	1.33 33.8	1.72 43.8	1.02 26	1.50 38	1.50 38.0	3000
-H-CWP20	1 1/4	1.67 42.5	2.09 53.1	1.34 34	1.73 44	1.81 46.0	3000
-H-CWP24	1 1/2	1.91 48.6	2.35 59.6	1.57 40	1.89 48	1.97 50	3000
-H-CWP4-X	1/4	0.55 14	0.87 22	0.24 6	1.02 26	0.94 23.8	3000
-H-CWP6-X	3/8	0.67 17	1.06 27	0.31 8	1.10 28	1.06 27	6000
-H-CWP8-X	1/2	0.85 21.7	1.30 33	0.43 11	1.18 30	1.18 30	6000
-H-CWP12-X	3/4	1.06 27	1.54 39	0.58 14.8	1.42 36	1.30 33.0	6000
-H-CWP16-X	1	1.33 33.8	1.89 48	0.79 20	1.50 38	1.81 46.0	6000
-H-CWP20-X	1 1/4	1.67 42.5	2.24 57	1.13 28.7	1.73 44	1.97 50	6000
-H-CWP24-X	1 1/2	1.91 48.6	2.52 64	1.31 33.2	1.89 48	2.28 58	6000

后面加-x为加厚型

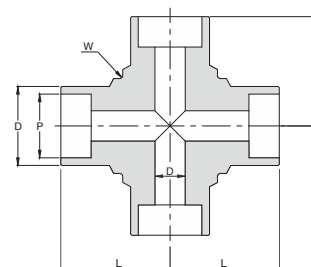

Pipe公称管承插焊半管接头

基本订购号	公称管 in	焊孔P in (mm)	外径D in (mm)	孔径d in (mm)	长度L in (mm)	压力等级 psi
-CWB4	1/4	0.55 14	0.79 20	0.31 8	0.87 22	3000
-CWB6	3/8	0.67 17	0.94 24	0.39 10	1.02 26	3000
-CWB8	1/2	0.85 21.7	1.14 29	0.59 15	1.26 32	3000
-CWB12	3/4	1.06 27	1.40 35.5	0.79 20	1.42 36	3000
-CWB16	1	1.33 33.8	1.72 43.8	1.02 26	1.65 42	3000
-CWB20	1 1/4	1.67 42.5	2.09 53.1	1.34 34	1.81 46	3000
-CWB24	1 1/2	1.91 48.6	2.35 59.6	1.57 40	1.97 50	3000
-CWB4-X	1/4	0.55 14	0.87 22	0.24 6	0.87 22	3000
-CWB6-X	3/8	0.67 17	1.06 27	0.31 8	1.02 26	6000
-CWB8-X	1/2	0.85 21.7	1.30 33	0.43 11	1.26 32	6000
-CWB12-X	3/4	1.06 27	1.54 39	0.58 14.8	1.42 36	6000
-CWB16-X	1	1.33 33.8	1.89 48	0.79 20	1.65 42	6000
-CWB20-X	1 1/4	1.67 42.5	2.24 57	1.13 28.7	1.81 46	6000
-CWB24-X	1 1/2	1.91 48.6	2.52 64	1.31 33.2	1.97 50	6000

后面加-x为加厚型

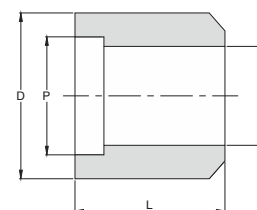

Pipe公称管承插焊管帽

基本订购号	公称管 in	焊孔P in (mm)	外径D in (mm)	长度L in (mm)	压力等级 psi
-DWM4	1/4	0.55 14	0.79 20	0.55 14	3000
-DWM6	3/8	0.67 17	0.94 24	0.63 16	3000
-DWM8	1/2	0.85 21.7	1.14 29	0.71 18	3000
-DWM12	3/4	1.06 27	1.40 35.5	0.83 21	3000
-DWM16	1	1.33 33.8	1.72 43.8	0.91 23	3000
-DWM20	1 1/4	1.67 42.5	2.09 53.1	0.98 25	3000
-DWM24	1 1/2	1.91 48.6	2.35 59.6	1.10 28	3000
-DWM4-X	1/4	0.55 14	0.87 22	0.59 15	6000
-DWM6-X	3/8	0.67 17	1.06 27	0.71 18	6000
-DWM8-X	1/2	0.85 21.7	1.30 33	0.79 20	6000
-DWM12-X	3/4	1.06 27	1.54 39	0.91 23	6000
-DWM16-X	1	1.33 33.8	1.89 48	1.02 26	6000
-DWM20-X	1 1/4	1.67 42.5	2.24 57	1.14 29	6000
-DWM24-X	1 1/2	1.91 48.6	2.52 64	1.26 32	6000

后面加-x为加厚型

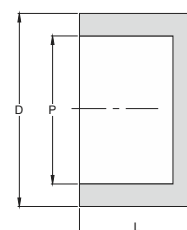

焊接管接头

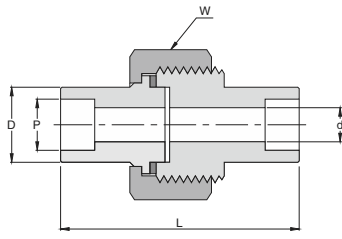

Pipe公称管承插焊活接

基本订购号	公称管 in	焊孔P in (mm)	外径D in (mm)	孔径d in (mm)	长度L in (mm)	六角W in (mm)	压力等级 psi
-HJ-CWP-4	1/4	0.55 14	0.79 20	0.31 8	1.57 40	1.57 40	3000
-HJ-CWP-6	3/8	0.67 17	0.94 24	0.39 10	1.73 44	1.73 44	3000
-HJ-CWP-8	1/2	0.85 21.7	1.14 29	0.59 15	1.97 50	1.97 50	3000
-HJ-CWP-12	3/4	1.06 27	1.40 35.5	0.79 20	2.28 58	2.36 60	3000
-HJ-CWP-16	1	1.33 33.8	1.69 42.8	1.02 26	2.44 62	2.76 70	3000
-HJ-CWP-20	1 1/4	1.67 42.5	2.09 53.1	1.34 34	2.83 72	3.15 80	3000
-HJ-CWP-24	1 1/2	1.91 48.6	2.35 59.6	1.57 40	2.99 76	3.54 90	3000

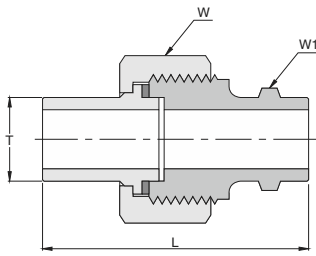

Tube管对焊活接

基本订购号	DN mm	外径T in (mm)	六角W in (mm)	六角W1 in (mm)	长度L in (mm)	压力等级 psi
-HJ-DWT10M	6	0.39 10	1.18 30	0.55 14	2.20 56	4800
-HJ-DWT14M	8	0.55 14	1.42 36	0.67 17	3.07 78	4800
-HJ-DWT18M	10	0.71 18	1.54 39	0.87 22	3.39 86	4800
-HJ-DWT22M	15	0.87 22	1.61 41	0.94 24	3.62 92	4800
-HJ-DWT27M	20	1.06 27	1.81 46	1.18 30	3.94 100	4800
-HJ-DWT34M	25	1.34 34	2.17 55	1.42 36	4.33 110	4800

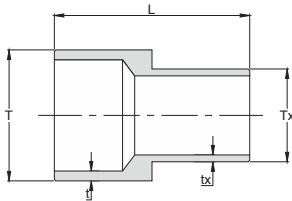

对焊异径直通接头

基本订购号	T in/mm	Tx in/mm	厚度t in (mm)	厚度tx in (mm)	长度L in (mm)	压力等级 psi
-U-DWT6-DWT4	3/8	1/4	0.035 0.9	0.035 0.9	1.18 30	3600
-U-DWT8-DWT4	1/2	1/4	0.049 1.2	0.049 1.2	1.26 32	3300
-U-DWT8-DWT6	1/2	3/8	0.049 1.2	0.049 1.2	1.34 34	3300
-U-DWT12-DWT8	3/4	1/2	0.049 1.2	0.049 1.2	1.42 36	2400
-U-DWT16-DWT8	1	1/2	0.065 1.7	0.049 1.2	1.50 38	2400
-U-DWT16-DWT12	1	3/4	0.065 1.7	0.049 1.2	1.50 38	2100
-U-DWT10M-DWT6M	10	6	0.039 1.0	0.039 1.0	1.18 30	3500
-U-DWT10M-DWT8M	10	8	0.039 1.0	0.039 1.0	1.18 30	3500
-U-DWT12M-DWT6M	12	6	0.039 1.0	0.039 1.0	1.26 32	3100
-U-DWT12M-DWT8M	12	8	0.039 1.0	0.039 1.0	1.26 32	3100
-U-DWT12M-DWT10M	12	10	0.039 1.0	0.039 1.0	1.34 34	3100
-U-DWT18M-DWT6M	18	6	0.059 1.5	0.059 1.5	1.42 36	2900
-U-DWT18M-DWT12M	18	12	0.059 1.5	0.059 1.5	1.50 38	2900

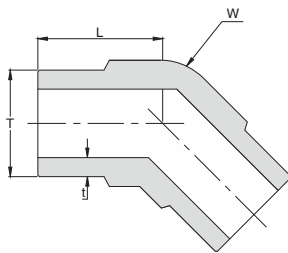

对焊45°弯头

基本订购号	外径T in/mm	厚度t in (mm)	长度L in (mm)	六角W in (mm)	压力等级 psi
-V-DWT2	1/8	0.028 0.7	0.51 13	0.31 7.9	5500
-V-DWT4	1/4	0.035 0.9	0.63 16	0.37 9.5	5100
-V-DWT6	3/8	0.035 0.9	0.75 19	0.50 12.7	3300
-V-DWT8	1/2	0.049 1.2	0.83 21	0.56 14.2	3700
-V-DWT12	3/4	0.049 1.2	0.98 25	0.82 20.8	3100
-V-DWT16	1	0.065 1.7	1.10 28	1.06 27	2800
-V-DWT6M	6	0.039 1.0	0.51 13	0.31 7.9	6000
-V-DWT8M	8	0.039 1.0	0.63 16	0.37 9.5	4500
-V-DWT10M	10	0.039 1.0	0.75 19	0.50 12.7	3400
-V-DWT12M	12	0.039 1.0	0.83 21	0.56 14.2	2900
-V-DWT14M	14	0.039 1.5	0.91 23	0.69 17.4	2900
-V-DWT16M	16	0.059 1.5	0.94 24	0.69 17.4	2900
-V-DWT18M	18	0.059 1.5	0.98 25	0.75 19	2800

对焊直角接头

基本订购号	外径T in/mm	厚度t in (mm)	长度L in (mm)	六角W in (mm)	压力等级 psi
-L-DWT2	1/8	0.028 0.7	0.51 13	0.31 7.9	5500
-L-DWT4	1/4	0.035 0.9	0.63 16	0.37 9.5	5100
-L-DWT6	3/8	0.035 0.9	0.75 19	0.50 12.7	3300
-L-DWT8	1/2	0.049 1.2	0.83 21	0.56 14.2	3700
-L-DWT12	3/4	0.049 1.2	0.98 25	0.82 20.8	3100
-L-DWT16	1	0.065 1.7	1.10 28	1.06 27	2800
-L-DWT6M	6	0.039 1.0	0.51 13	0.31 7.9	6000
-L-DWT8M	8	0.039 1.0	0.63 16	0.37 9.5	4500
-L-DWT10M	10	0.039 1.0	0.75 19	0.50 12.7	3400
-L-DWT12M	12	0.039 1.0	0.83 21	0.56 14.2	2900
-L-DWT14M	14	0.059 1.5	0.91 23	0.69 17.4	2900
-L-DWT16M	16	0.059 1.5	0.94 24	0.69 17.4	2900
-L-DWT18M	18	0.059 1.5	0.98 25	0.75 19	2800

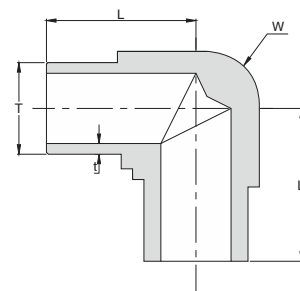

对焊三通接头

基本订购号	外径T in/mm	厚度t in (mm)	长度L in (mm)	六角W in (mm)	压力等级 psi
-T-DWT2	1/8	0.028 0.7	0.51 13	0.31 7.9	5500
-T-DWT4	1/4	0.035 0.9	0.63 16	0.37 9.5	5100
-T-DWT6	3/8	0.035 0.9	0.75 19	0.50 12.7	3300
-T-DWT8	1/2	0.049 1.2	0.83 21	0.56 14.2	3700
-T-DWT12	3/4	0.049 1.2	0.98 25	0.82 20.8	3100
-T-DWT16	1	0.065 1.7	1.10 28	1.06 27	2800
-T-DWT6M	6	0.039 1.0	0.51 13	0.31 7.9	6000
-T-DWT8M	8	0.039 1.0	0.63 16	0.37 9.5	4500
-T-DWT10M	10	0.039 1.0	0.75 19	0.50 12.7	3400
-T-DWT12M	12	0.039 1.0	0.83 21	0.56 14.2	2900
-T-DWT14M	14	0.059 1.5	0.91 23	0.69 17.4	2900
-T-DWT16M	16	0.059 1.5	0.94 24	0.69 17.4	2900
-T-DWT18M	18	0.059 1.5	0.98 25	0.75 19	2800

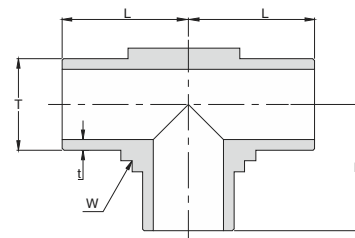

对焊四通接头

基本订购号	外径T in/mm	厚度t in (mm)	长度L in (mm)	六角W in (mm)	压力等级 psi
-H-DWT2	1/8	0.028 0.7	0.51 13	0.31 7.9	5500
-H-DWT4	1/4	0.035 0.9	0.63 16	0.37 9.5	5100
-H-DWT6	3/8	0.035 0.9	0.75 19	0.50 12.7	3300
-H-DWT8	1/2	0.049 1.2	0.83 21	0.56 14.2	3700
-H-DWT12	3/4	0.049 1.2	0.98 25	0.82 20.8	3100
-H-DWT16	1	0.065 1.7	1.10 28	1.06 27	2800
-H-DWT6M	6	0.039 1.0	0.51 13	0.31 7.9	6000
-H-DWT8M	8	0.039 1.0	0.63 16	0.37 9.5	4500
-H-DWT10M	10	0.039 1.0	0.75 19	0.50 12.7	3400
-H-DWT12M	12	0.039 1.0	0.83 21	0.56 14.2	2900
-H-DWT14M	14	0.059 1.5	0.91 23	0.69 17.4	2900
-H-DWT16M	16	0.059 1.5	0.94 24	0.69 17.4	2900
-H-DWT18M	18	0.059 1.5	0.98 25	0.75 19	2800

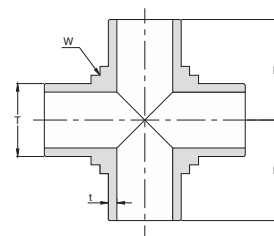

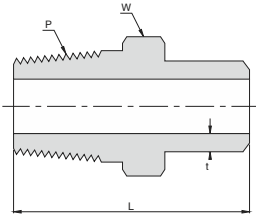

NPT外螺纹对焊直通接头

基本订购号	外径T in mm	厚度t in (mm)	外螺纹P (NPT)	长度L in (mm)	六角W in (mm)	压力等级 psi
-U-T2-DWT4	1/4	0.049 1.2	1/8	1.02 26	0.44 11.1	3250
-U-T2-DWT6	3/8	0.049 1.2	1/8	1.14 29	0.44 11.1	2500
-U-T4-DWT6	3/8	0.049 1.2	1/4	1.26 32	0.56 14.2	2500
-U-T2-DWT8	1/2	0.065 1.7	1/8	1.13 33	0.56 14.2	2400
-U-T4-DWT8	1/2	0.065 1.7	1/4	1.46 37	0.56 14.2	2100
-U-T4-DWT12	3/4	0.095 2.4	1/4	1.69 43	0.87 22.2	2000
-U-T6-DWT12	3/4	0.095 2.4	3/8	1.77 45	0.87 22.2	2000
-U-T8-DWT12	3/4	0.095 2.4	1/2	1.89 48	0.87 22.2	1800
-U-T8-DWT16	1	0.109 2.8	1/2	2.09 53	1.06 27.0	1800
-U-T2-DWT8M	8	0.079 2.0	1/8	1.02 26	0.44 11.1	4000
-U-T4-DWT8M	8	0.079 2.0	1/4	1.18 30	0.56 14.2	3800
-U-T2-DWT10M	10	0.079 2.0	1/8	1.18 30	0.56 14.2	3800
-U-T4-DWT10M	10	0.079 2.0	1/4	1.26 32	0.56 14.2	3700
-U-T4-DWT14M	14	0.098 2.5	1/4	1.50 48	0.62 15.8	3560
-U-T6-DWT14M	14	0.098 2.5	3/8	1.57 40	0.69 17.4	3560
-U-T6-DWT16M	16	0.118 3.0	3/8	1.69 43	0.69 17.4	3650
-U-T8-DWT16M	16	0.118 3.0	1/2	1.81 46	0.87 22.2	3650
-U-T6-DWT20M	20	0.157 4.0	3/8	1.85 47	0.87 22.2	3650
-U-T8-DWT20M	20	0.157 4.0	1/2	1.97 50	0.87 22.2	3650

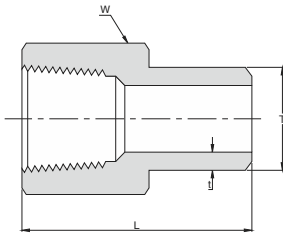

NPT内螺纹对焊直通接头

基本订购号	外径T in mm	厚度t in (mm)	内螺纹P (NPT)	长度L in (mm)	六角W in (mm)	压力等级 psi
-U-TF2-DWT6	3/8	0.049 1.2	1/8	1.02 26	0.56 14.2	2600
-U-TF2-DWT8	1/2	0.065 1.7	1/8	1.14 29	0.56 14.2	2600
-U-TF2-DWT10	5/8	0.083 2.1	1/8	1.26 32	0.69 17.4	2100
-U-TF4-DWT10	5/8	0.083 2.1	1/4	1.34 34	0.75 19.0	2100
-U-TF4-DWT12	3/4	0.095 2.4	1/4	1.57 40	0.87 22.2	2000
-U-TF6-DWT12	3/4	0.095 2.4	3/8	1.69 43	0.87 22.2	2000
-U-TF6-DWT16	1	0.109 2.8	3/8	1.89 48	1.06 27.0	1800
-U-TF8-DWT16	1	0.109 2.8	1/2	2.09 53	1.06 27.0	1800
-U-TF2-DWT8M	8	0.079 2.0	1/8	1.02 26	0.56 14.2	3000
-U-TF2-DWT10M	10	0.079 2.0	1/8	1.10 28	0.56 14.2	3000
-U-TF4-DWT12M	12	0.094 2.4	1/4	1.26 32	0.69 17.4	3200
-U-TF4-DWT14M	14	0.098 2.5	1/4	1.42 36	0.69 17.4	3200
-U-TF6-DWT16M	16	0.118 3.0	3/8	1.57 40	0.87 22.2	3000
-U-TF6-DWT18M	18	0.118 3.0	3/8	1.69 43	0.87 22.2	3000
-U-TF6-DWT20M	20	0.157 4.0	3/8	1.89 48	0.87 22.2	2500
-U-TF8-DWT22M	22	0.157 4.0	1/2	1.97 50	1.06 27.0	2500
-U-TF8-DWT25M	25	0.177 4.5	1/2	2.09 53	1.06 27.0	2500

米制外螺纹活接焊直通接头

基本订购号	焊管D in (mm)	外螺纹P (M)	通径d (M)	长度L in (mm)	长度L1 in (mm)	六角W1 in (mm)	六角W2 in (mm)
-U-HDW6M-M10	0.24 6	M10X1	0.12 3	1.89 48	0.35 9	0.55 14	0.67 17
-U-HDW10M-M10	0.39 10	M10X1	0.24 6	2.09 53	0.35 9	0.67 17	0.75 19
-U-HDW10M-M14	0.39 10	M14X1.5	0.24 6	2.28 58	0.47 12	0.75 19	0.75 19
-U-HDW14M-M14	0.55 14	M14X1.5	0.31 8	2.52 64	0.47 12	0.87 22	0.94 24
-U-HDW14M-M18	0.55 14	M18X1.5	0.31 8	2.68 68	0.55 14	0.94 24	0.94 24
-U-HDW18M-M18	0.71 18	M18X1.5	0.47 12	2.99 76	0.55 14	1.06 27	1.06 27
-U-HDW18M-M22	0.71 18	M22X1.5	0.47 12	2.99 76	0.55 14	1.06 27	1.06 27
-U-HDW22M-M22	0.87 22	M22X1.2	0.59 15	3.03 77	0.55 14	1.26 32	1.34 34
-U-HDW22M-M27	0.87 22	M27X2	0.59 15	3.19 81	0.63 16	1.34 34	1.34 34
-U-HDW28M-M27	1.10 28	M27X2	0.79 20	3.39 86	0.63 16	1.34 34	1.54 39
-U-HDW28M-M33	1.10 28	M33X2	0.79 20	3.39 86	0.63 16	1.54 39	1.54 39
-U-HDW34M-M33	1.34 34	M33X2	0.98 25	3.66 93	0.63 16	1.65 42	1.81 46
-U-HDW34M-M42	1.34 34	M42X2	0.98 25	3.86 98	0.71 18	1.81 46	1.81 46
-U-HDW42M-M42	1.65 42	M42X2	1.26 32	3.94 100	0.71 18	1.97 50	2.17 55
-U-HDW42M-M48	1.65 42	M48X2	1.26 32	4.06 103	0.79 20	2.17 55	2.17 55

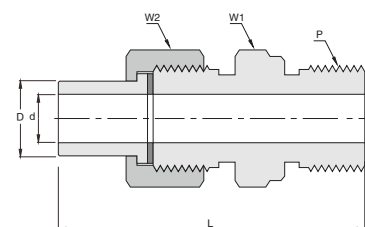

NPT外螺纹活接焊直通接头

基本订购号	焊管D in (mm)	外螺纹P (NPT)	通径d (M)	长度L in (mm)	长度L1 in (mm)	六角W1 in (mm)	六角W2 in (mm)
-U-HDW6M-T2	0.24 6	1/8	0.12 3	1.97 50	0.35 9	0.55 14	0.67 17
-U-HDW10M-T2	0.39 10	1/8	0.24 6	2.20 56	0.35 9	0.67 17	0.75 19
-U-HDW6M-T4	0.24 6	1/4	0.12 3	2.05 52	0.51 13	0.55 14	0.67 17
-U-HDW10M-T4	0.39 10	1/4	0.24 6	2.13 54	0.51 13	0.67 17	0.75 19
-U-HDW10M-T6	0.39 10	3/8	0.24 6	2.44 62	0.55 14	0.67 17	0.75 19
-U-HDW12M-T6	0.47 12	3/8	0.31 8	2.60 66	0.55 14	0.75 19	0.87 22
-U-HDW14M-T6	0.55 14	3/8	0.31 8	2.68 68	0.55 14	0.87 22	0.94 24
-U-HDW18M-T6	0.71 18	3/8	0.47 12	2.76 70	0.55 14	1.06 27	1.06 27
-U-HDW12M-T8	0.47 12	1/2	0.31 8	2.76 70	0.67 17	0.87 22	0.87 22
-U-HDW14M-T8	0.55 14	1/2	0.31 8	2.83 72	0.67 17	0.87 22	0.94 24
-U-HDW18M-T8	0.71 18	1/2	0.47 12	2.91 74	0.67 17	1.06 27	1.18 30
-U-HDW22M-T8	0.87 22	1/2	0.59 15	2.99 76	0.67 17	1.08 30	1.26 32
-U-HDW18M-T12	0.71 18	3/4	0.47 12	2.99 76	0.75 19	1.06 27	1.18 30
-U-HDW22M-T12	0.87 22	3/4	0.59 15	3.07 78	0.75 19	1.18 30	1.26 32
-U-HDW25M-T12	0.98 25	3/4	0.71 18	3.15 80	0.75 19	1.26 32	1.34 34
-U-HDW28M-T12	1.10 28	3/4	0.79 20	3.23 82	0.75 19	1.34 34	1.42 36
-U-HDW25M-T16	0.98 25	1	0.71 18	3.39 86	0.87 22	1.34 34	1.42 36
-U-HDW28M-T16	1.10 28	1	0.79 20	3.54 90	0.87 22	1.34 34	1.42 36
-U-HDW34M-T16	1.34 34	1	0.98 25	3.78 96	0.87 22	1.61 41	1.81 46
-U-HDW34M-T20	1.34 34	1 1/4	0.98 25	3.86 98	0.91 23	1.61 41	1.81 46
-U-HDW42M-T20	1.65 42	1 1/4	1.26 32	3.94 100	0.91 23	1.97 50	2.17 55
-U-HDW34M-T24	1.65 42	1 1/2	1.26 32	4.49 114	0.98 25	1.97 50	2.17 55

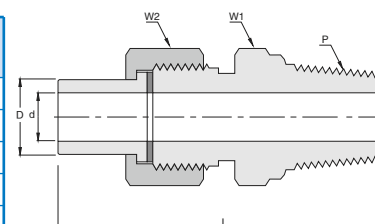

活接焊直通接头

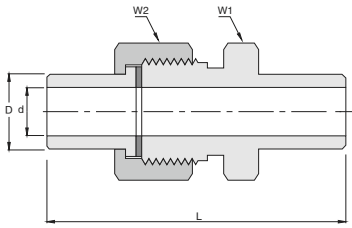

基本订购号	焊管D in (mm)	通径d in (mm)	长度L in (mm)	六角W1 in (mm)	六角W2 in (mm)
-U-HDW6M	0.24 6	0.12 3	1.81 46	0.55 14	0.67 17
-U-HDW10M	0.39 10	0.24 6	2.05 52	0.67 17	0.75 19
-U-HDW12M	0.47 12	0.31 8	2.20 56	0.75 19	0.87 22
-U-HDW14M	0.55 14	0.31 8	2.36 60	0.87 22	0.94 24
-U-HDW18M	0.71 18	0.47 12	2.76 70	1.06 27	1.06 27
-U-HDW22M	0.87 22	0.59 15	2.91 74	1.18 30	1.26 32
-U-HDW25M	0.98 25	0.71 18	3.07 78	1.34 34	1.34 34
-U-HDW28M	1.10 28	0.79 20	3.23 82	1.34 34	1.42 36
-U-HDW34M	1.34 34	0.98 25	3.54 90	1.61 41	1.81 46
-U-HDW42M	1.65 42	1.26 32	3.86 98	1.97 50	2.17 55

活接焊直通穿板接头

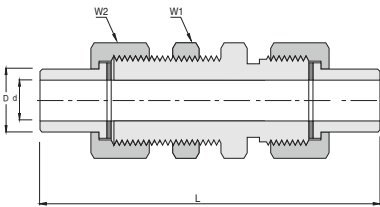

基本订购号	焊管D in (mm)	通径d in (mm)	长度L in (mm)	六角W1 in (mm)	六角W2 in (mm)
-BU-HDW6M	0.24 6	0.12 3	3.78 96	0.55 14	0.67 17
-BU-HDW10M	0.39 10	0.24 6	3.94 100	0.67 17	0.75 19
-BU-HDW12M	0.47 12	0.31 8	4.17 106	0.75 19	0.87 22
-BU-HDW14M	0.55 14	0.31 8	4.41 112	0.87 22	0.94 24
-BU-HDW18M	0.71 18	0.47 12	4.96 126	1.06 27	1.06 27
-BU-HDW22M	0.87 22	0.59 15	5.43 138	1.18 30	1.26 32
-BU-HDW25M	0.98 25	0.71 18	5.59 142	1.34 34	1.34 34
-BU-HDW28M	1.10 28	0.79 20	5.91 150	1.34 34	1.42 36
-BU-HDW34M	1.34 34	0.98 25	6.30 160	1.61 41	1.81 46
-BU-HDW42M	1.65 42	1.26 32	7.01 178	1.97 50	2.17 55

米制外螺纹活接焊直通接头

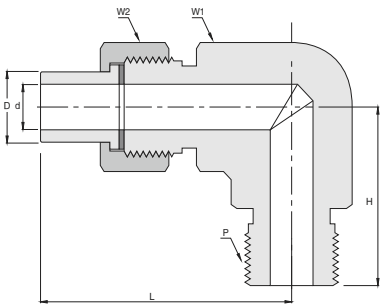

基本订购号	焊管D in (mm)	外螺纹P (M)	通径d (M)	长度L in (mm)	高度H in (mm)	六角W1 in (mm)	六角W2 in (mm)
-L-HDW6M-M10	0.24 6	M10X1	0.12 3	1.89 48	0.79 20	0.55 14	0.67 17
-L-HDW10M-M10	0.39 10	M10X1	0.24 6	1.97 50	0.87 22	0.67 17	0.75 19
-L-HDW10M-M14	0.39 10	M14X1.5	0.24 6	2.05 52	0.91 23	0.75 19	0.75 19
-L-HDW14M-M14	0.55 14	M14X1.5	0.31 8	2.20 56	0.98 25	0.87 22	0.94 24
-L-HDW14M-M18	0.55 14	M18X1.5	0.31 8	2.28 58	1.18 30	0.94 24	0.94 24
-L-HDW18M-M18	0.71 18	M18X1.5	0.47 12	2.60 66	1.30 33	1.06 27	1.06 27
-L-HDW18M-M22	0.71 18	M22X1.5	0.47 12	2.60 66	1.38 35	1.06 27	1.06 27
-L-HDW22M-M22	0.87 22	M22X1.2	0.59 15	2.76 70	1.50 38	1.26 32	1.34 34
-L-HDW22M-M27	0.87 22	M27X2	0.59 15	2.83 72	1.54 39	1.34 34	1.34 34
-L-HDW28M-M27	1.10 28	M27X2	0.79 20	3.15 80	1.61 41	1.34 34	1.54 39
-L-HDW28M-M33	1.10 28	M33X2	0.79 20	3.23 82	1.61 41	1.54 39	1.54 39
-L-HDW34M-M33	1.34 34	M33X2	0.98 25	3.54 90	1.69 43	1.65 42	1.81 46
-L-HDW34M-M42	1.34 34	M42X2	0.98 25	3.62 92	1.85 47	1.81 46	1.81 46
-L-HDW42M-M42	1.65 42	M42X2	1.26 32	3.94 100	1.93 49	1.97 50	2.17 55
-L-HDW42M-M48	1.65 42	M48X2	1.26 32	4.06 103	2.13 54	2.17 55	2.17 55

NPT外螺纹活接焊直角接头

基本订购号	焊管D in (mm)	外螺纹P (NPT)	通径d (M)	长度L in (mm)	高度H in (mm)	六角W1 in (mm)	六角W2 in (mm)
-L-HDW6M-T2	0.24 6	1/8	0.12 3	1.97 50	0.79 20	0.55 14	0.67 17
-L-HDW10M-T2	0.39 10	1/8	0.24 6	2.20 56	0.87 22	0.67 17	0.75 19
-L-HDW6M-T4	0.24 6	1/4	0.12 3	2.05 52	0.87 22	0.55 14	0.67 17
-L-HDW10M-T4	0.39 10	1/4	0.24 6	2.13 54	0.91 23	0.67 17	0.75 19
-L-HDW10M-T6	0.39 10	3/8	0.24 6	2.44 62	0.94 24	0.67 17	0.75 19
-L-HDW12M-T6	0.47 12	3/8	0.31 8	2.60 66	1.02 26	0.75 19	0.87 22
-L-HDW14M-T6	0.55 14	3/8	0.31 8	2.68 68	1.10 28	0.87 22	0.94 24
-L-HDW18M-T6	0.71 18	3/8	0.47 12	2.76 70	1.18 30	1.06 27	1.06 27
-L-HDW12M-T8	0.47 12	1/2	0.31 8	2.76 70	1.26 32	0.87 22	0.87 22
-L-HDW14M-T8	0.55 14	1/2	0.31 8	2.83 72	1.34 34	0.87 22	0.94 24
-L-HDW18M-T8	0.71 18	1/2	0.47 12	2.91 74	1.42 36	1.06 27	1.18 30
-L-HDW22M-T8	0.87 22	1/2	0.59 15	2.99 76	1.50 38	1.08 30	1.26 32
-L-HDW18M-T12	0.71 18	3/4	0.47 12	2.99 76	1.46 37	1.06 27	1.18 30
-L-HDW22M-T12	0.87 22	3/4	0.59 15	3.07 78	1.57 40	1.18 30	1.26 32
-L-HDW25M-T12	0.98 25	3/4	0.71 18	3.15 80	1.61 41	1.26 32	1.34 34
-L-HDW28M-T12	1.10 28	3/4	0.79 20	3.23 82	1.65 42	1.34 34	1.42 36
-L-HDW25M-T16	0.98 25	1	0.71 18	3.39 86	1.65 42	1.34 34	1.42 36
-L-HDW28M-T16	1.10 28	1	0.79 20	3.54 90	1.69 43	1.34 34	1.42 36
-L-HDW34M-T16	1.34 34	1	0.98 25	3.78 96	1.69 43	1.61 41	1.81 46
-L-HDW34M-T20	1.34 34	1 1/4	0.98 25	3.86 98	1.89 48	1.61 41	1.81 46
-L-HDW42M-T20	1.65 42	1 1/4	1.26 32	3.94 100	1.93 49	1.97 50	2.17 55
-L-HDW34M-T24	1.65 42	1 1/2	1.26 32	4.49 114	2.01 51	1.97 50	2.17 55

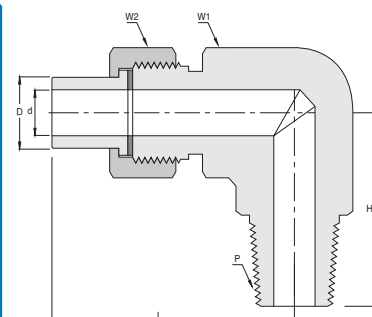

活接焊直角穿板接头

基本订购号	焊管D in (mm)	通径d in (mm)	长度L in (mm)	高度H in (mm)	六角W1 in (mm)	六角W2 in (mm)
-BL-HDW6M	0.24 6	0.12 3	2.60 66	1.65 42	0.55 14	0.67 17
-BL-HDW10M	0.39 10	0.24 6	2.91 74	1.97 50	0.67 17	0.75 19
-BL-HDW12M	0.47 12	0.31 8	3.15 80	2.13 54	0.75 19	0.87 22
-BL-HDW14M	0.55 14	0.31 8	3.39 86	2.28 58	0.87 22	0.94 24
-BL-HDW18M	0.71 18	0.47 12	3.62 92	2.60 66	1.06 27	1.06 27
-BL-HDW22M	0.87 22	0.59 15	3.94 100	2.76 70	1.18 30	1.26 32
-BL-HDW25M	0.98 25	0.71 18	4.17 106	2.91 74	1.34 34	1.34 34
-BL-HDW28M	1.10 28	0.79 20	4.33 110	3.07 78	1.34 34	1.42 36
-BL-HDW34M	1.34 34	0.98 25	4.72 120	3.46 88	1.61 41	1.81 46
-BL-HDW42M	1.65 42	1.26 32	5.28 134	3.86 98	1.97 50	2.17 55

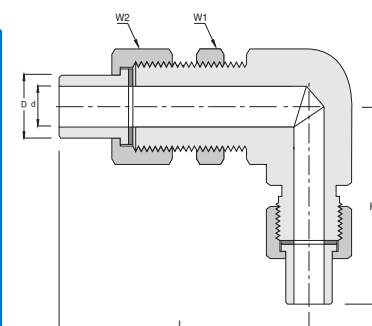

活接焊三通接头

基本订购号	焊管D in (mm)	通径d in (mm)	长度L in (mm)	高度H in (mm)	六角W1 in (mm)	六角W2 in (mm)
-T-HDW6M	0.24 6	0.12 3	3.31 84	1.65 42	0.55 14	0.67 17
-T-HDW10M	0.39 10	0.24 6	3.94 100	1.97 50	0.67 17	0.75 19
-T-HDW12M	0.47 12	0.31 8	4.25 108	2.13 54	0.75 19	0.87 22
-T-HDW14M	0.55 14	0.31 8	4.57 116	2.28 58	0.87 22	0.94 24
-T-HDW18M	0.71 18	0.47 12	5.20 132	2.60 66	1.06 27	1.06 27
-T-HDW22M	0.87 22	0.59 15	5.51 140	2.76 70	1.18 30	1.26 32
-T-HDW25M	0.98 25	0.71 18	5.83 148	2.91 74	1.34 34	1.34 34
-T-HDW28M	1.10 28	0.79 20	6.14 156	3.07 78	1.34 34	1.42 36
-T-HDW34M	1.34 34	0.98 25	6.93 176	3.46 88	1.61 41	1.81 46
-T-HDW42M	1.65 42	1.26 32	7.72 196	3.86 98	1.97 50	2.17 55

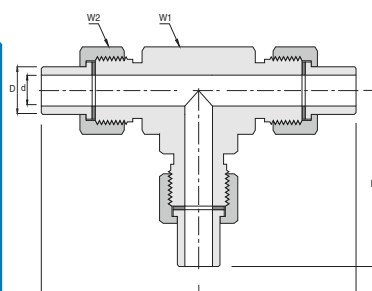

焊接管接头

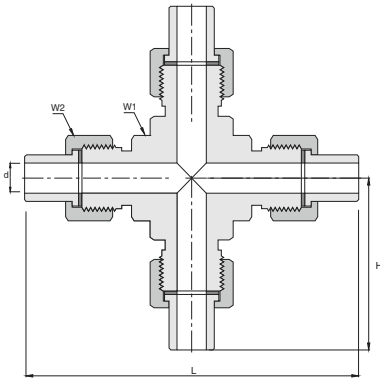

活接焊四通接头

基本订购号	焊管D in (mm)	通径d in (mm)	长度L in (mm)	高度H in (mm)	六角W1 in (mm)	六角W2 in (mm)
-H-HDW6M	0.24 6	0.12 3	3.31 84	1.65 42	0.55 14	0.67 17
-H-HDW10M	0.39 10	0.24 6	3.94 100	1.97 50	0.67 17	0.75 19
-H-HDW12M	0.47 12	0.31 8	4.25 108	2.13 54	0.75 19	0.87 22
-H-HDW14M	0.55 14	0.31 8	4.57 116	2.28 58	0.87 22	0.94 24
-H-HDW18M	0.71 18	0.47 12	5.20 132	2.60 66	1.06 27	1.06 27
-H-HDW22M	0.87 22	0.59 15	5.51 140	2.76 70	1.18 30	1.26 32
-H-HDW25M	0.98 25	0.71 18	5.83 148	2.91 74	1.34 34	1.34 34
-H-HDW28M	1.10 28	0.79 20	6.14 156	3.07 78	1.34 34	1.42 36
-H-HDW34M	1.34 34	0.98 25	6.93 176	3.46 88	1.61 41	1.81 46
-H-HDW42M	1.65 42	1.26 32	7.72 196	3.86 98	1.97 50	2.17 55

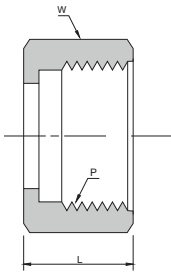

活接焊螺母

基本订购号	管径D in (mm)	螺纹P (M)	长度L in (mm)	六角W in (mm)
-HDM6M	0.24 6	M12X1.25	0.47 12	0.67 17
-HDM10M	0.39 10	M16X1.5	0.55 14	0.75 19
-HDM12M	0.47 12	M20X1.5	0.63 16	0.87 24
-HDM14M	0.55 14	M22X1.5	0.67 17	0.94 27
-HDM18M	0.71 18	M27X1.5	0.79 20	1.06 32
-HDM22M	0.87 22	M30X1.5	0.83 21	1.26 36
-HDM25M	0.98 25	M33X2	0.83 21	1.34 39
-HDM28M	1.10 28	M36X2	0.87 22	1.42 41
-HDM34M	1.34 34	M42X2	1.02 26	1.81 50
-HDM42M	1.65 42	M52X2	1.10 28	2.17 60

活接焊短管平口式

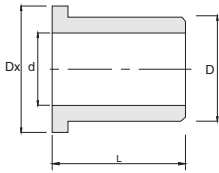

基本订购号	管径D in (mm)	通径d in (mm)	外径Dx in (mm)	长度L in (mm)
-HDA6M	0.24 6	0.12 3	0.39 10	0.79 20
-HDA10M	0.39 10	0.24 6	0.55 14	0.94 24
-HDA12M	0.47 12	0.31 8	0.71 18	1.02 26
-HDA14M	0.55 14	0.39 10	0.79 20	1.10 28
-HDA18M	0.71 18	0.47 12	0.94 24	1.26 32
-HDA22M	0.87 22	0.59 15	1.06 27	1.26 32
-HDA25M	0.98 25	0.71 18	1.18 30	1.38 35
-HDA28M	1.10 28	0.79 20	1.30 33	1.38 35
-HDA34M	1.34 34	0.98 25	1.54 39	1.50 38
-HDA42M	1.65 42	1.26 32	1.93 49	1.57 40

活接焊短管凸起式

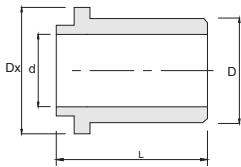

基本订购号	管径D in (mm)	通径d in (mm)	外径Dx in (mm)	长度L in (mm)
-HDB6M	0.24 6	0.12 3	0.39 10	0.98 25
-HDB10M	0.39 10	0.24 6	0.55 14	1.14 29
-HDB12M	0.47 12	0.31 8	0.71 18	1.26 32
-HDB14M	0.55 14	0.39 10	0.79 20	1.30 33
-HDB18M	0.71 18	0.47 12	0.94 24	1.46 37
-HDB22M	0.87 22	0.59 15	1.06 27	1.50 38
-HDB25M	0.98 25	0.71 18	1.18 30	1.57 40
-HDB28M	1.10 28	0.79 20	1.30 33	1.61 41
-HDB34M	1.34 34	0.98 25	1.54 39	1.73 44
-HDB42M	1.65 42	1.26 32	1.93 49	1.81 46

24°锥密封焊接短管

基本订购号	外径T mm	内径D in (mm)	长度L in (mm)	O圈尺寸 内径x线径
-HZP-8M	8	0.20 5	1.14 29	6.0x1.5
-HZP-10M	10	0.24 6	1.26 32	7.5x1.5
-HZP-12M	12	0.31 8	1.30 33	9.0x1.5
-HZP-14M	14	0.39 10	1.34 34	10.0x1.5
-HZP-16M	16	0.43 11	1.50 38	12.0x1.5
-HZP-20M	20	0.59 15	1.69 43	16.3x1.5
-HZP-25M	25	0.67 17	1.97 50	20.3x2.4
-HZP-30M	30	0.87 22	2.05 52	25.3x2.4
-HZP-38M	38	1.02 26	2.20 56	33.3x2.4

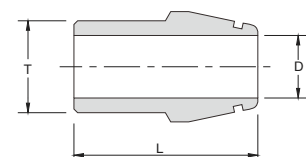

24°锥密封焊接螺母

基本订购号	外径T mm	内径D in (mm)	长度L in (mm)	O圈尺寸 内径x线径
-HZM-8M	8	0.20 5	1.14 29	6.0x1.5
-HZM-10M	10	0.24 6	1.26 32	7.5x1.5
-HZM-12M	12	0.31 8	1.30 33	9.0x1.5
-HZM-14M	14	0.39 10	1.34 34	10.0x1.5
-HZM-16M	16	0.43 11	1.50 38	12.0x1.5
-HZM-20M	20	0.59 15	1.69 43	16.3x1.5
-HZM-25M	25	0.67 17	1.97 50	20.3x2.4
-HZM-30M	30	0.87 22	2.05 52	25.3x2.4
-HZM-38M	38	1.02 26	2.20 56	33.3x2.4

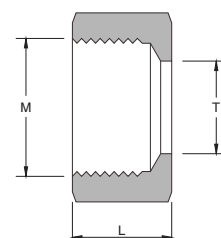

24°锥密封焊接外螺纹直通

基本订购号	外径T mm	螺纹P	内径D in (mm)	长度L in (mm)	六角W in (mm)
-U-HZG8M-G4	8	G1/4	0.20 5	1.77 45	0.75 19
-U-HZG12M-G6	12	G3/8	0.31 8	1.89 48	0.87 22
-U-HZG16M-G8	16	G1/2	0.43 11	2.01 51	1.06 27
-U-HZG20M-G12	20	G3/4	0.59 15	2.13 54	1.26 32
-U-HZG25M-G16	25	G1	0.67 17	2.28 58	1.61 41
-U-HZG8M-T4	8	NPT1/4	0.20 5	1.77 45	0.67 17
-U-HZG12M-T6	12	NPT3/8	0.31 8	1.89 48	0.87 22
-U-HZG16M-T8	16	NPT1/2	0.43 11	2.01 51	1.06 27
-U-HZG20M-T12	20	NPT3/4	0.59 15	2.13 54	1.26 32
-U-HZG25M-T16	25	NPT1	0.67 17	2.28 58	1.54 39

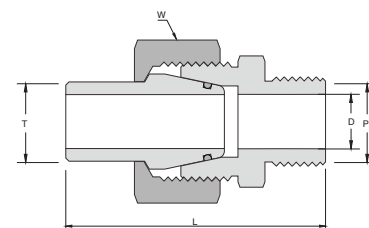

焊接管接头

24°锥密封焊接外螺纹直角

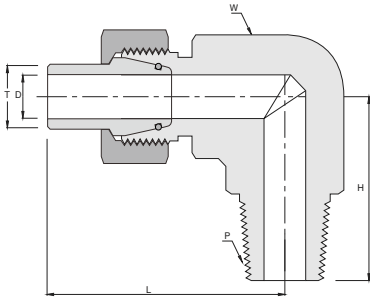

基本订购号	焊管T (mm)	外螺纹P (NPT)	通径D in (mm)	长度L in (mm)	高度H in (mm)	六角W in (mm)
-L-HZG8M-T4	8	1/4	0.20 5	1.89 48	0.79 20	0.55 14
-L-HZG10M-T6	10	3/8	0.24 6	1.97 50	0.87 22	0.67 17
-L-HZG12M-T6	12	3/8	0.31 8	2.13 54	0.87 22	0.55 14
-L-HZG16M-T8	16	1/2	0.43 11	2.52 64	0.91 23	0.67 17
-L-HDW20M-T12	20	3/4	0.59 15	2.91 74	0.94 24	0.67 17
-L-HDW25M-T16	25	1	0.67 17	3.27 83	1.02 26	0.75 19

24°锥密封焊接三通

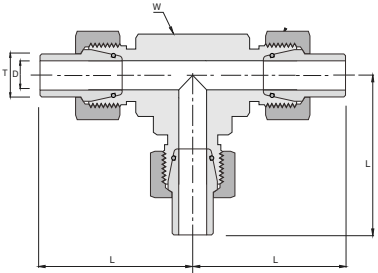

基本订购号	外径T mm	内径D in (mm)	长度L in (mm)	六角W in (mm)
-T-HZG8M	8	0.20 5	1.89 48	0.69 17.4
-T-HZG10M	10	0.24 6	1.97 50	0.75 19
-T-HZG12M	12	0.31 8	2.13 54	0.82 20.8
-T-HZG16M	16	0.43 11	2.52 64	0.94 23.8
-T-HZG20M	20	0.59 15	2.91 74	1.06 27
-T-HZG25M	25	0.67 17	3.27 83	1.30 33
-T-HZG30M	30	0.87 22	3.62 92	1.50 38
-T-HZG38M	38	1.02 26	4.13 105	1.81 46

24°锥密封焊接四通

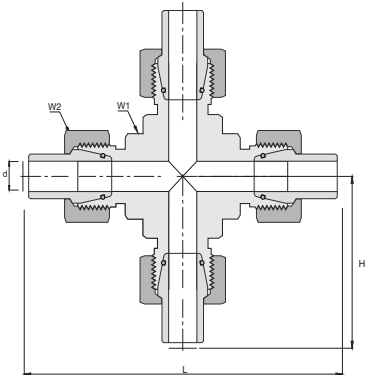

基本订购号	外径T mm	内径D in (mm)	长度L in (mm)	六角W in (mm)
-H-HZG8M	8	0.20 5	1.89 48	0.69 17.4
-H-HZG10M	10	0.24 6	1.97 50	0.75 19
-H-HZG12M	12	0.31 8	2.13 54	0.82 20.8
-H-HZG16M	16	0.43 11	2.52 64	0.94 23.8
-H-HZG20M	20	0.59 15	2.91 74	1.06 27
-H-HZG25M	25	0.67 17	3.27 83	1.30 33
-H-HZG30M	30	0.87 22	3.62 92	1.50 38
-H-HZG38M	38	1.02 26	4.13 105	1.81 46

北京尼克福斯阀门科技有限责任公司

地址:北京市大兴区丽园路港悦大厦7号楼1101
电话:86-010-66117795
传真:86-010-63733307 网址:www.nikfus.cn
邮编:100071 邮箱:sale1@nikfus.com

沧州尼克福斯仪表有限公司

地址:河北省沧州市南皮工业区
手机:13811443727 (微信同号)
邮编:061599 网址:www.nikfus.cn